



**casagrande**

**C4**

# HYDRAULIC CRAWLER DRILL

perforatrice idraulica





# TECHNICAL SPECIFICATIONS

DATI TECNICI

C4

CARATTERISTICHE CARRO		UNDERCARRIAGE	
Larghezza sottocarro		Overall width of undercarriage	1800 mm
Larghezza pattini		Track shoes width	300 mm
Lunghezza cingoli		Overall track length	2234 mm
Velocità di traslazione		Travel speed	0 + 1,8 km/h
Pendenza max. superabile		Max. gradeability	20°
Pressione specifica al suolo		Ground pressure	7 N/cm <sup>2</sup>
MOTORE		ENGINE	
Modello		Model	<b>CUMMINS</b> QSB 4,5-TAA (EPA/COM III)
Potenza a 2200 giri		Rated power at 2200 rpm	82 kW
Capacità serbatoio gasolio		Fuel tank capacity	170 l
Capacità serbatoio olio idraulico		Hydraulic oil tank capacity	350 l
MAST		MAST	
Lunghezza mast		Mast length	<b>2800</b> 3350 MR
Corsa testa di rotazione		Strokes of rotary head	2800 mm 3350 mm
Forza di estrazione		Extraction force	45 kN 30 kN
Spinta sull'utensile		Crowd force	27 kN 30 kN
MORSE		CLAMPS	
Diametro		Diameter	<b>M2Z/M2SZ</b> 40 ÷ 254 mm
Forza di chiusura		Clamping force	145 kN
TESTA DI ROTAZIONE		ROTARY HEAD	
Coppia max.		Max. torque	<b>H800</b> 8200 Nm
Giri max.		Max. speed	330 rpm
INGOMBRI E PESO		DIMENSIONS AND WEIGHT	
Lunghezza		Length	5570 mm
Larghezza		Width	1800 mm
Altezza		Height	2532 mm
Peso attrezzatura*		Weight of rig*	~ 8000 kg

\* Dipende dall'allestimento montato

\* Depending on mounted equipment

## TRANSPORT DIMENSIONS

DIMENSIONI DI TRASPORTO

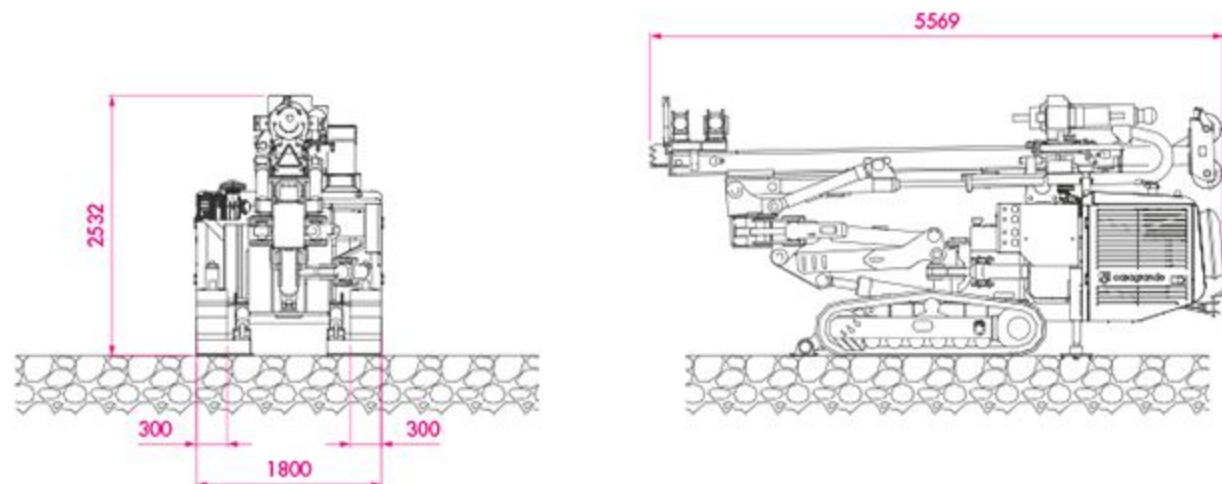

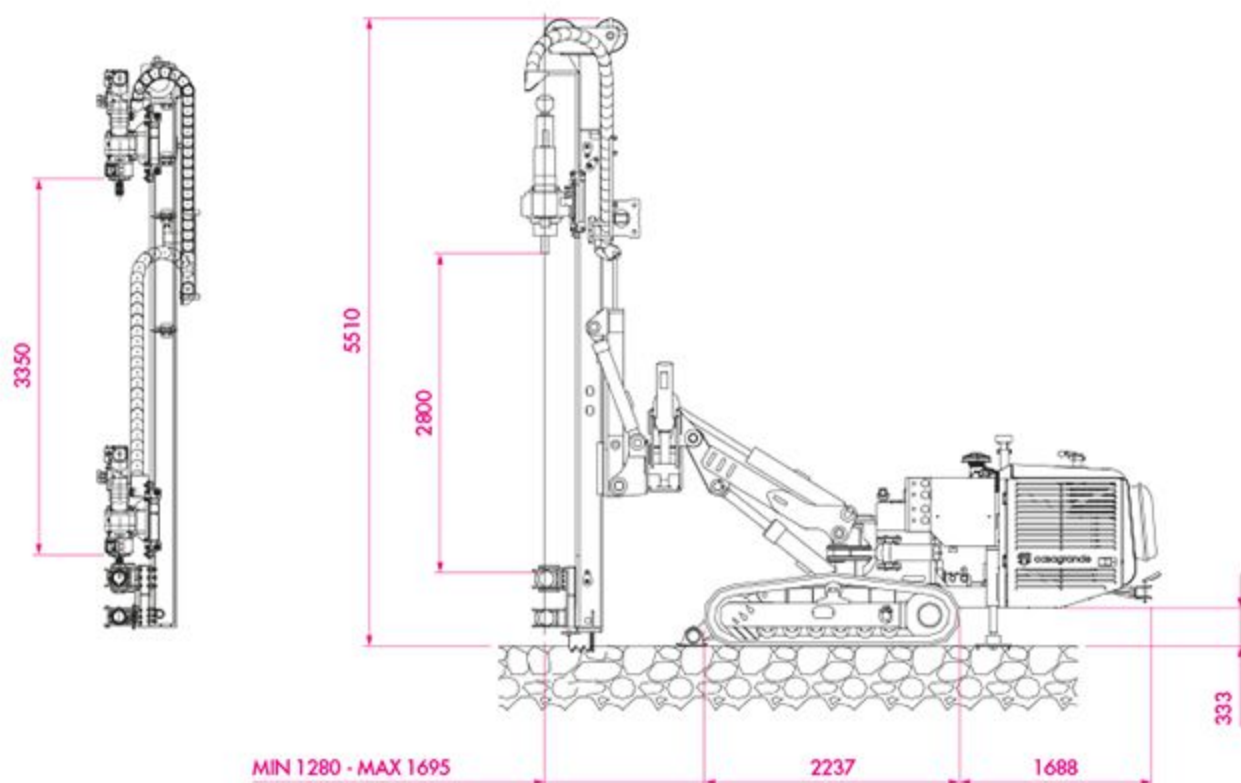

MAST 4930/3350  
GEAR BOX FEED  
MOTORIDUTTORE

MAST 4370/2800  
CYLINDER FEED  
CILINDRO

## MAST MOVEMENTS

MOVIMENTAZIONI MAST

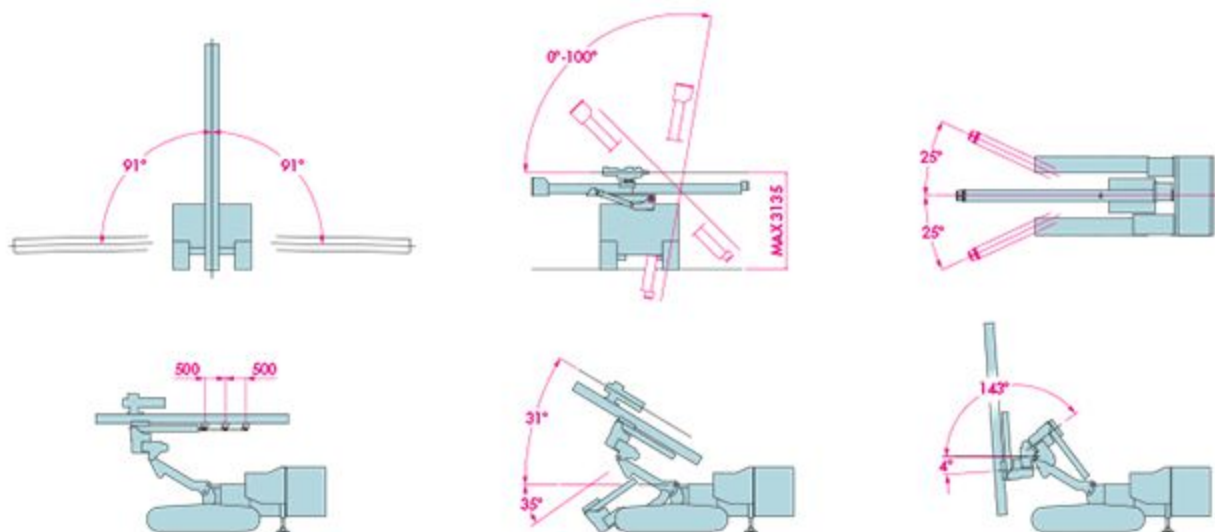

JET GROUTING EQUIPMENT  
ALLESTIMENTO JET GROUTING

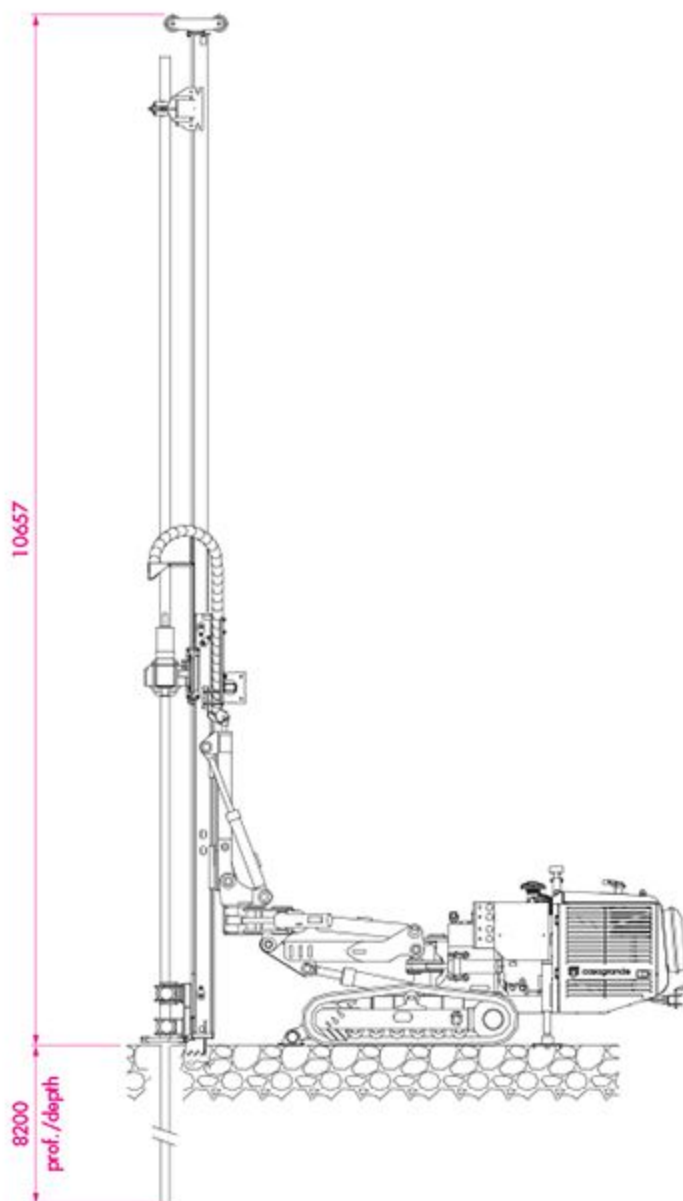
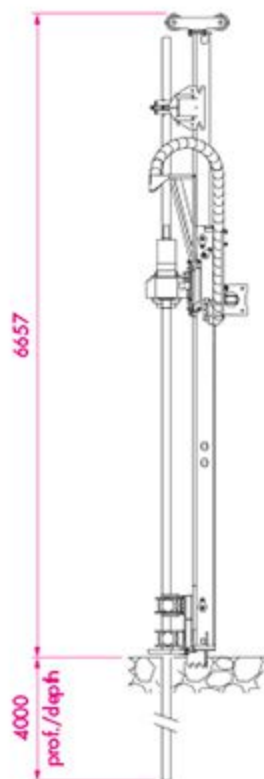

Martello Casagrande D21

Altre teste e martelli su richiesta

Mandrino P114

Impianto jet

Prolunga tralicciata 2 m

Prolunga tralicciata 6 m per jet

Argano di servizio A2, tiro 20 kN

Prolunga 2,5 m. per falchetto

Pompa a vite per fango tipo NG530L: 24 bar – 170 l/min

Pompa schiumogeni tipo C35: 50 bar – 30 l/min

Pompa triplex per acqua tipo P246: 40 bar – 200 l/min

Pompa scarotatrice

Oliatore 8 l

Casagrande hammer D21

Other rotary heads and hammers on request

Hydraulic chuck P114

Jet system

2 m. extension for jet grouting

6 m. extension for jet grouting

A2 type hydraulic service winch, line pull 20 kN

2,5 m extension for jib

Screw pump for foam flushing type NG530L: 24 bar – 170 l/min

Foam pump type C35: 50 bar – 30 l/min

Triplex water pump type P246: 40 bar – 200 l/min

Core ejection pump

8 l. oil liner



ITALY



SLOVENIA

## MAST MOVEMENTS FTW

MOVIMENTAZIONI MAST FTW

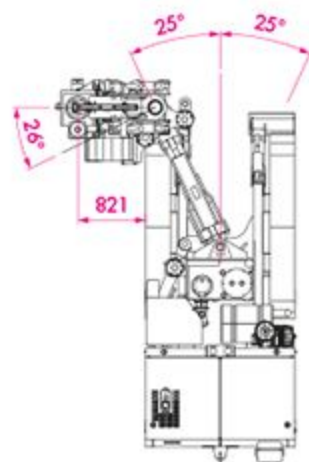
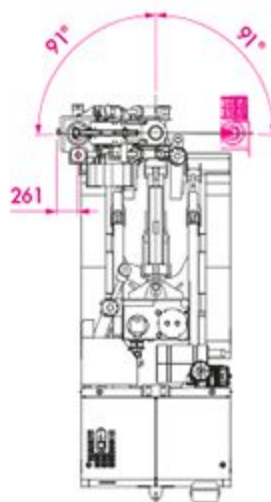
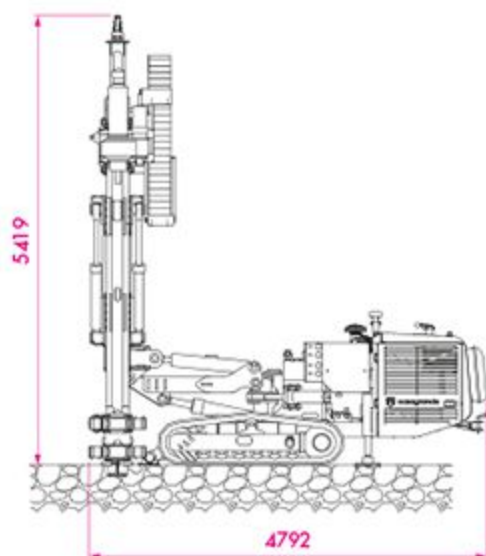



SWITZERLAND



U.S.A.

GERMANY



SOUTH AFRICA

