

TT5

ADVANCED COMPACT ROTARY RIG



**Innovative
features**

**Compact
dimensions**

**Multipurpose
drilling modes**

rev 1.2021



**Versatile
working setup**

**Flexibility
at work**

**Simplicity
of use**

**Best in class
for low headroom
jobsites**

**Low ground
pressure**



SCHEDA TECNICA — KIT DI PERFORAZIONE

DATA SHEET — DRILLING KIT

TT5

Rotary idraulica

Sistema di bordo TSP

(Potenziometro di coppia/velocità)

Coppia max nominale

Velocità di perforazione

Velocità di scarico

Hydraulic rotary head

TSP on-board device

(torque/speed potentiometer)

Max nominal torque

Drilling speed

Spin-off speed

50 kNm – 36900 ft lbs

3 – 50 rpm

50 rpm

Argano Principale

Tiro sul 1° strato

Velocità max

Diametro della fune

Main winch

Line pull on 1st layer

Max line speed

Rope diameter

52 kN – 11700 lbs

63 m/min – 206 ft/min

16 mm – 0,62 in

Argano Ausiliario

Tiro sul 1° strato

Velocità max

Diametro della fune

Auxiliary winch

Line pull on 1st layer

Max line speed

Rope diameter

20 kN – 4500 lbs

95 m/min – 311 ft/min

14 mm – 0,55 in

Motoriduttore a catena

Forza di estrazione/spinta

Corsa

Corsa (con prolunga mast)

Crowd Chain-Motor System

Extraction/crowd force

Stroke

Stroke (with mast extension)

80 kN – 17984 lbs

5000 mm – 197 in

7000 mm – 275 in

TORQUE – SPEED

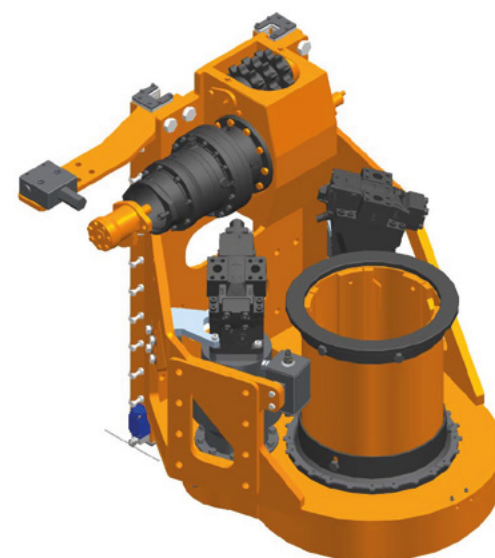
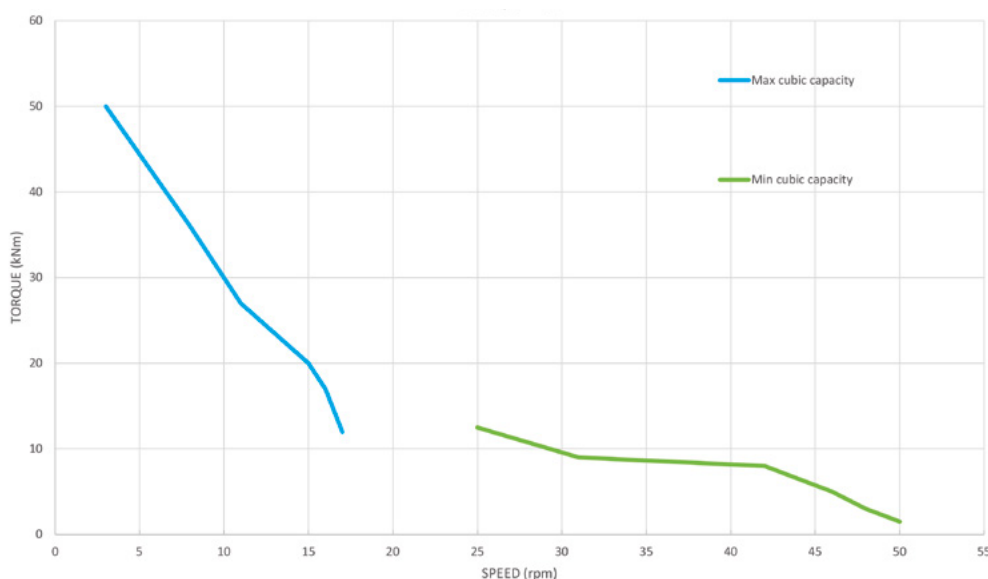

SCHEDA TECNICA — BASE CARRO

DATA SHEET — BASE CARRIER

TT5

Carro base

Carro base	Base Carrier	
Tipo	Type	Eurocomach ESP100 UR4
Motore diesel	Diesel engine	YANMAR 4TNV98CT
Normativa emissioni	Exhaust emission standard	EU Stage V - US EPA Tier4 Final
Potenza a 2100 rpm	Rated power @ 2100 rpm	53,7 kW – 73 HP
Capacità serbatoio carburante	Fuel tank capacity	200 l – 53 gal
Livello di pressione sonora in cabina	Sound pressure level in cabin	72 dB(A)
Livello di potenza sonora	Sound power level	102 dB(A)

Impianto idraulico

Impianto idraulico	Hydraulic System	
Portata pompe principali	Main pumps flow rate	1x 185 l/min – 1 x 49 gpm
Portata pompa secondaria	Auxiliary pump flow rate	20 l/min – 5,3 gpm
Pressione di lavoro	Working hydraulic pressure	280 bar – 4061 psi
Massima pressione	Max hydraulic pressure	300 bar – 4351 psi
Capacità serbatoio olio idraulico	Hydraulic oil tank capacity	90,0 l – 23,8 gal

Sottocarro

Sottocarro	Undercarriage	
Larghezza con cingoli chiusi	Width with retracted tracks	2320 mm – 90,5 in
Larghezza con cingoli aperti	Width with extended tracks	2920 mm – 113,9 in
Lunghezza cingoli (carro fisso)	Overall tracks length (fixed tracks)	2880 mm – 113,4 in
Lunghezza cingoli (carro allargabile)	Overall tracks length (expanding tracks)	3076 mm – 121,1 in
Larghezza pattini a tre barre	Width of triple grouser track shoes	450 mm – 17,6 in
Velocità di traslazione	Travel speed	5 Km/h – 3,1 mph
Forza di trazione	Traction force	115 kN – 25852 lbs

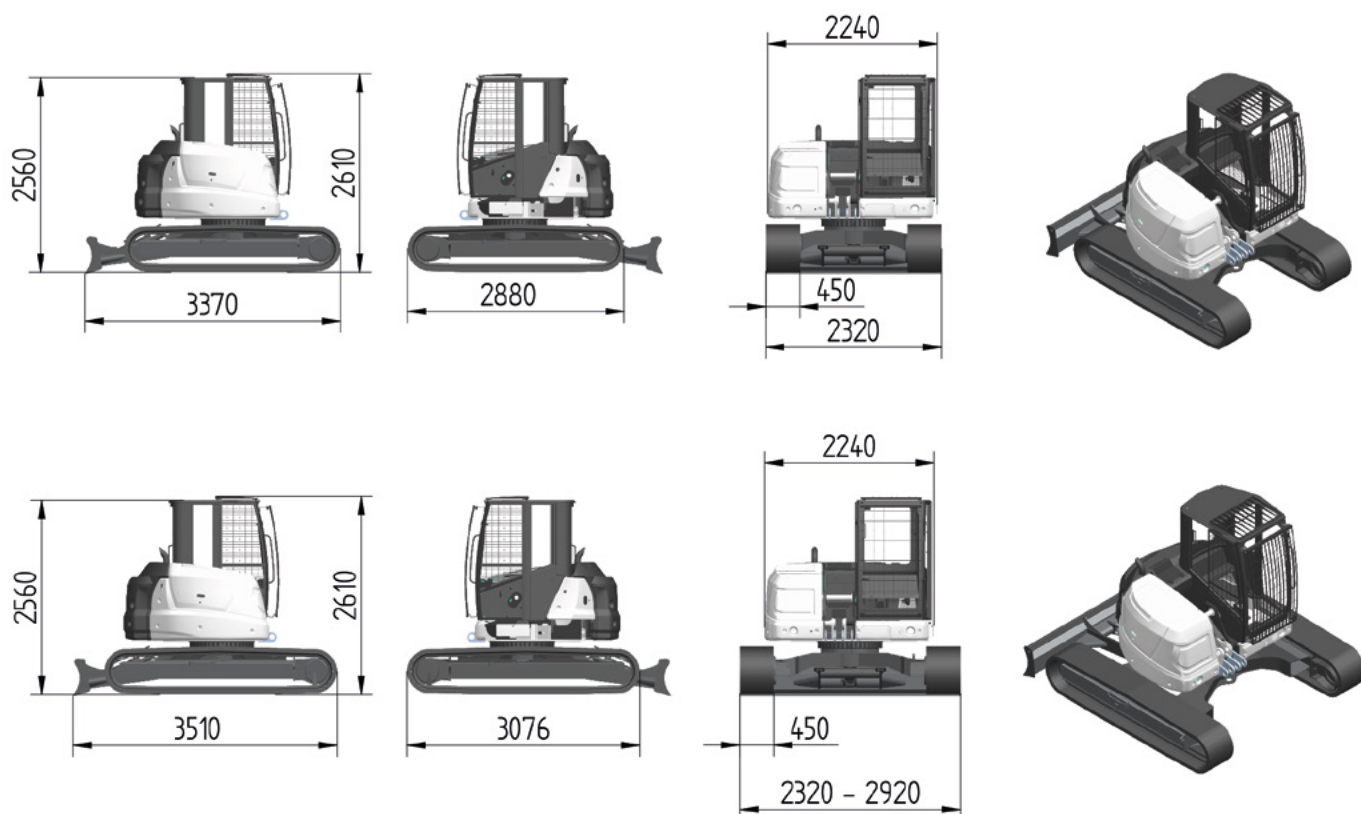

MODALITÀ DI TRASPORTO TRANSPORT MODE

TT5

Dimensioni per il trasporto

Larghezza

Peso (con Kelly Bar da 28m)

Transport dimensions

Width

Weight (with 28m kelly bar)

2320 mm – 7,6 ft

15500 kg – 34172 lbs

Trasporto via camion

Altezza in versione kelly bar

Lunghezza in versione kelly bar

Transport by truck

Height in kelly bar mode

Length in kelly bar mode

2970 mm – 9,74 ft

7690 mm – 25,2 ft

Spedizione via nave

Altezza

Lunghezza

La TT5 può essere stivata
in un container high-cube da 40'.

Shipment by vessel

Height

Length

The TT5 can be stowed
into a 40' high-cube container.

2560 mm – 8,4 ft

8090 mm – 26,5 ft

TRASPORTO VIA CAMION TRANSPORT BY TRUCK

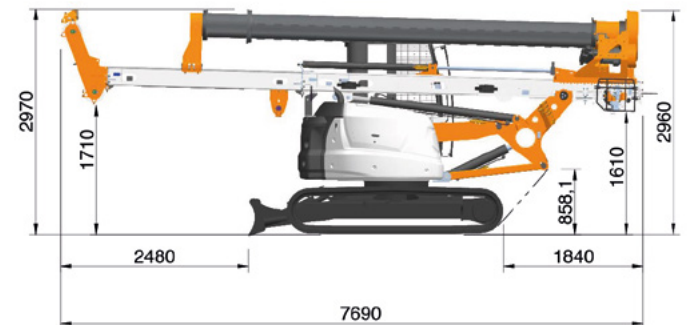

TRASPORTO VIA NAVE SHIPMENT BY VESSEL

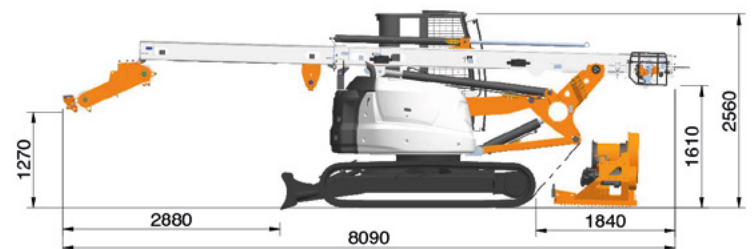

EQUIPAGGIAMENTO STANDARD

STANDARD EQUIPMENT

TT5

Motore diesel conforme alle norme EU Stage V / US EPA Tier 4 Final	<i>EU Stage V / US EPA Tier 4 Final compliant diesel engine</i>
Dispositivo di bordo TSP (Potenziometro di coppia/velocità)	<i>TSP device (Torque/Speed Potentiometer)</i>
Profondimetro elettronico con display digitale	<i>Depth measurement device with on-board screen</i>
Controllo automatico della cilindrata dei motori rotary	<i>Automatic control of rotary motors displacement</i>
Sistema di "contraccolpo rotary" per scarico rapido dell'utensile	<i>Rotary knockback system for quick tool discharge</i>
Argano principale e ausiliario a discesa controllata	<i>Main and auxiliary winch controlled descent type</i>
Interruttore fine-corsa sulla fune principale e ausiliaria	<i>Hoist limit switch on main and aux ropes</i>
Raccordi a innesto rapido	<i>Quick-release hydraulic couplers</i>
Testina girevole sulla fune principale	<i>Swivel head on main rope</i>
Punto di aggancio per la fune ausiliaria	<i>Aux rope hooking point</i>
Sottocarro in acciaio ad alta resistenza	<i>Heavy duty steel undercarriage</i>
Occhielli di ancoraggio per trasporto	<i>Transport security lugs on crawler units</i>
Guida-aste superiore	<i>Kelly bar top guide</i>
Flangia "battibacket" sotto la rotary	<i>Beating flange for bucket opening</i>
Sistema di illuminazione di bordo	<i>On-board lighting set</i>
Cassetta attrezzi a bordo	<i>On-board tool box</i>
Cabina conforme alla norma ROPS con ottima visibilità, sedile ergonomico regolabile, joystick di controllo, spie acustiche e luminose.	<i>ROPS compliant cab with optimum visibility, adjustable ergonomic seat, joystick controls, acoustic and optic warning</i>
Griglia di protezione cabina conforme alle norme FOPS	<i>FOPS compliant protective grid</i>
Sistema di riscaldamento e aria condizionata in cabina	<i>Heat and air conditioning system</i>
Videocamera posteriore con schermo a colori in cabina	<i>Rear view camera with on-board display</i>
Videocamera sull'argano principale con schermo a colori in cabina	<i>Main winch camera with on-board display</i>
Dispositivo per l'allineamento verticale del mast con schermo a bordo	<i>Mast verticality device with on-board screen</i>
Schermo digitale per il controllo dei parametri del motore	<i>Digital screen for engine parameters control</i>
Impianto Radio con lettore MP3 e porta USB	<i>Radio with MP3 player and USB plug</i>
Pulsante d'arresto d'emergenza a bordo	<i>Emergency stop button on-board</i>
Pulsante d'arresto d'emergenza esterno per operatore a terra	<i>Emergency stop button outside the cab</i>
Dispositivi fine-corsa sul falchetto, sul mast e sul pantografo	<i>Limit switches on the cathead, on the mast and on the parallelogram</i>

EQUIPAGGIAMENTO OPZIONALE

OPTIONAL EQUIPMENT

Motore diesel conforme alle norme EU Stage IIIA / US EPA Tier 3	<i>EU Stage IIIA - US EPA Tier 3 compliant diesel engine</i>
Sottocarro allargabile	<i>Variable gauge undercarriage</i>
Allineamento verticale automatico del mast	<i>Automatic vertical mast alignment</i>
Flangia sotto rotary per testa giracamie	<i>Rotary flange for casing pipes driving</i>
Giunto cardanico per la rotary	<i>Cardanic joint for rotary</i>
Prolunga mast per configurazioni di lavoro speciali	<i>Mast extension for special working configurations</i>
Computer di bordo per la misurazione dei parametri di perforazione, completo di software per trasferimento dati al PC	<i>Computer board for drilling parameter measurements, complete with software for processing the data to the PC</i>
Dispositivo elettronico di bordo compatibile con i requisiti tecnici richiesti dal Piano Nazionale 'INDUSTRIA 4.0' per l'acquisto di beni strumentali con Credito d'Imposta	<i>On-board electronic device compatible with the technical requirements of the Italian National Plan 'INDUSTRIA 4.0' for the purchase of capital goods with Tax Credit</i>

DETTAGLI TECNICI KELLY BARS KELLY BARS TECHNICAL DETAILS

TT5

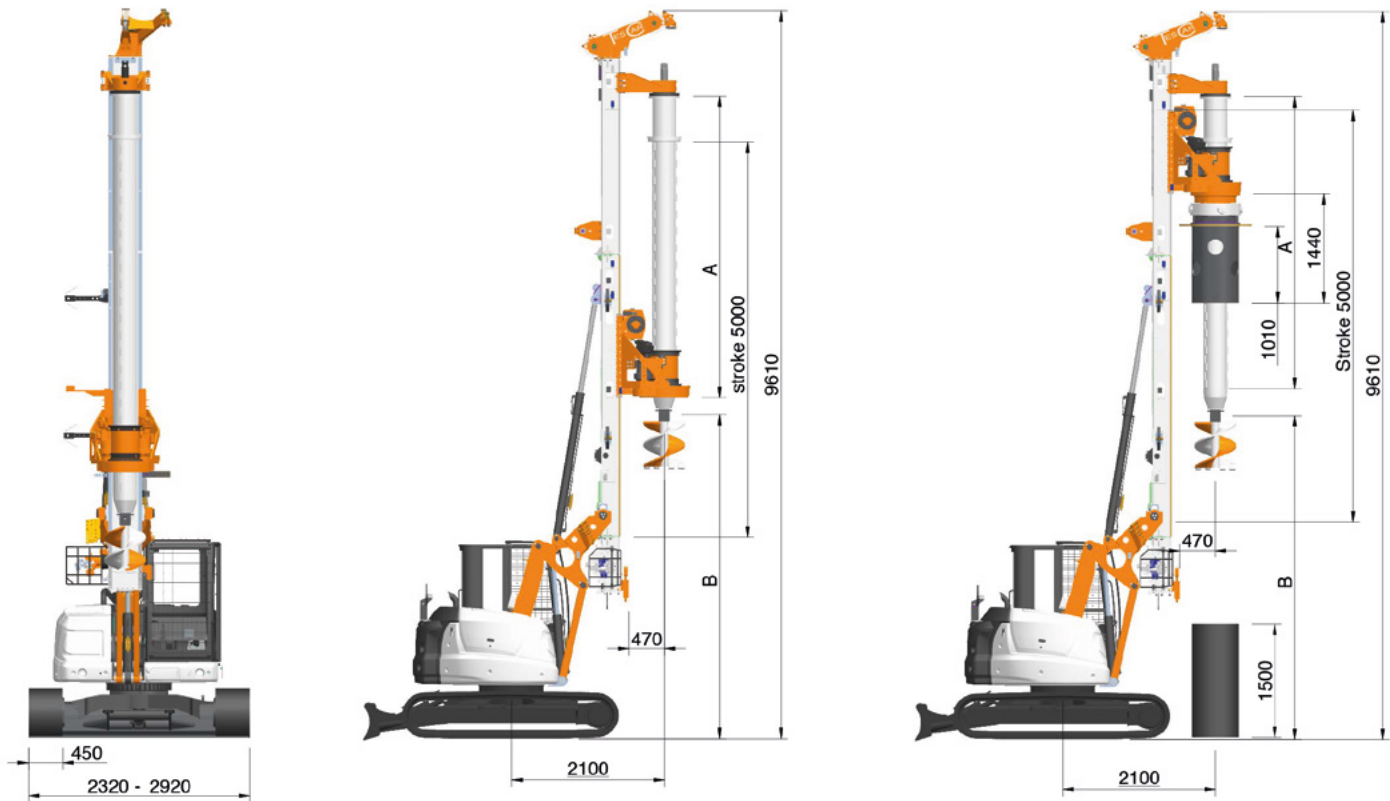

BL

Dimensioni delle Aste
Kelly Dimensions

Profondità
Depth

Peso
Weight

CCMS
System

A	H	B
n° elem x m	m - ft	ton
6 x 3,1	14 - 44,8	1,2
6 x 3,83	18 - 59	1,61
6 x 4,49	22 - 72,1	1,7
6 x 4,79	24 - 78,7	1,8
6 x 5,25	27 - 88,58	2,4

6 Elementi
6 Elements

PARAMETRI DI PERFORAZIONE DRILLING PARAMETERS

TT5

Pali	Kelly bar bored piling	
Diametro min	Min diameter	350 mm – 13,8 in
Diametro max fronte mast (CCMS)	Max diameter front mast (CCMS)	900 mm – 35,4 in
Diametro max sotto mast	Max diameter below mast	2000 mm – 78,7 in
Diametro max con tubi forma	Max diameter with casing pipes	620 mm – 24,4 in
Profondità max	Max depth	28 m – 91,8 ft

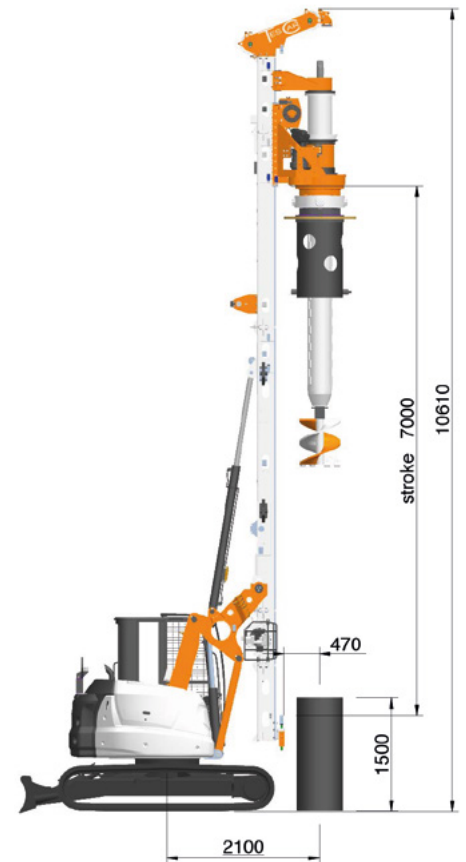
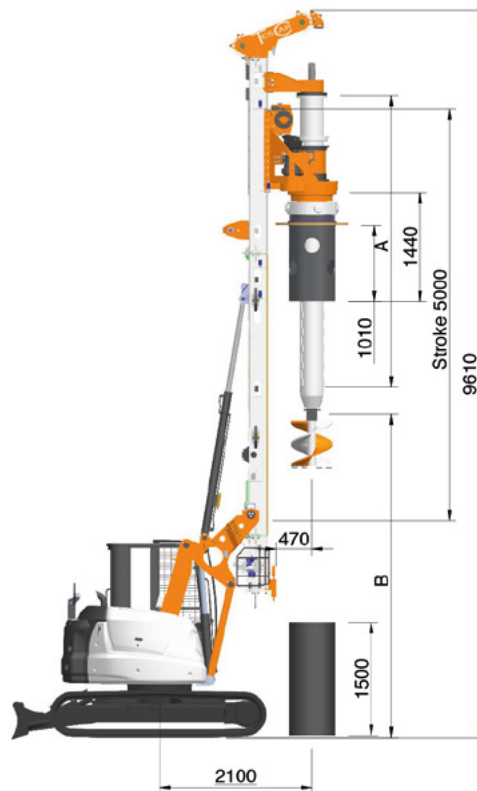
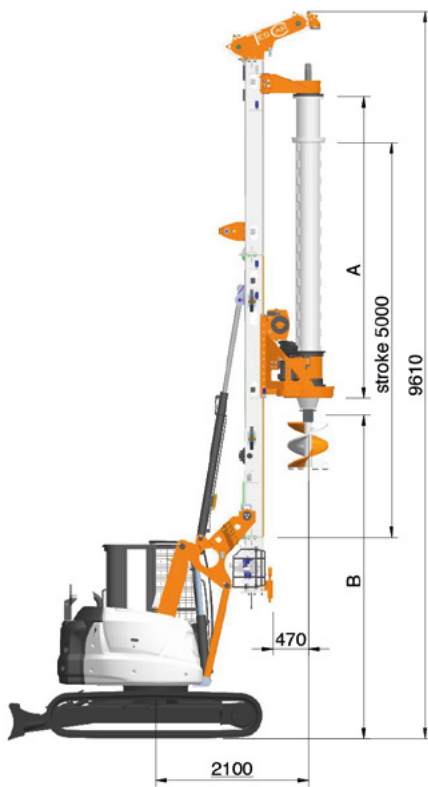



VERSIONE PER PALI CFA CFA BORED PILING

TT5

VERSIONE STANDARD STANDARD VERSION

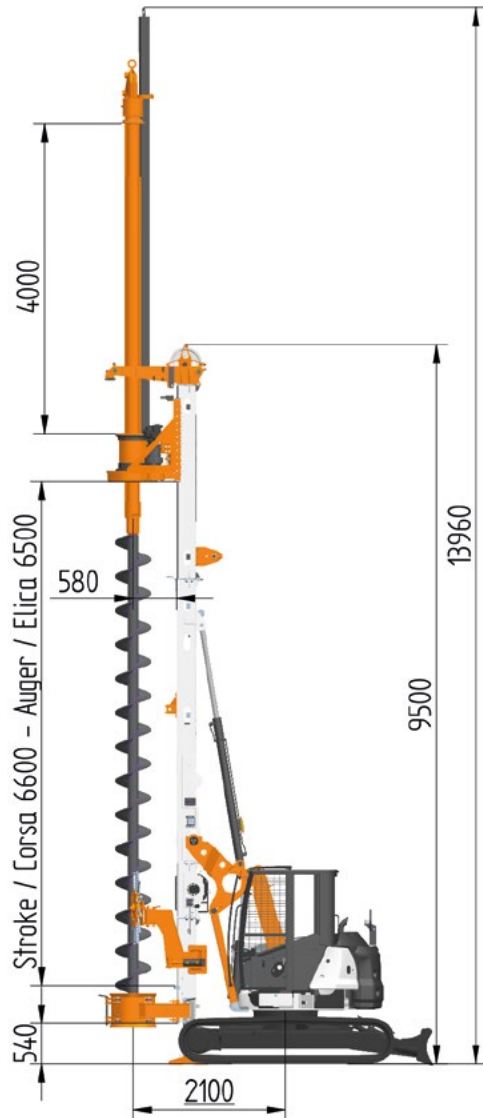

VERSIONE ALLUNGATA EXTENDED VERSION

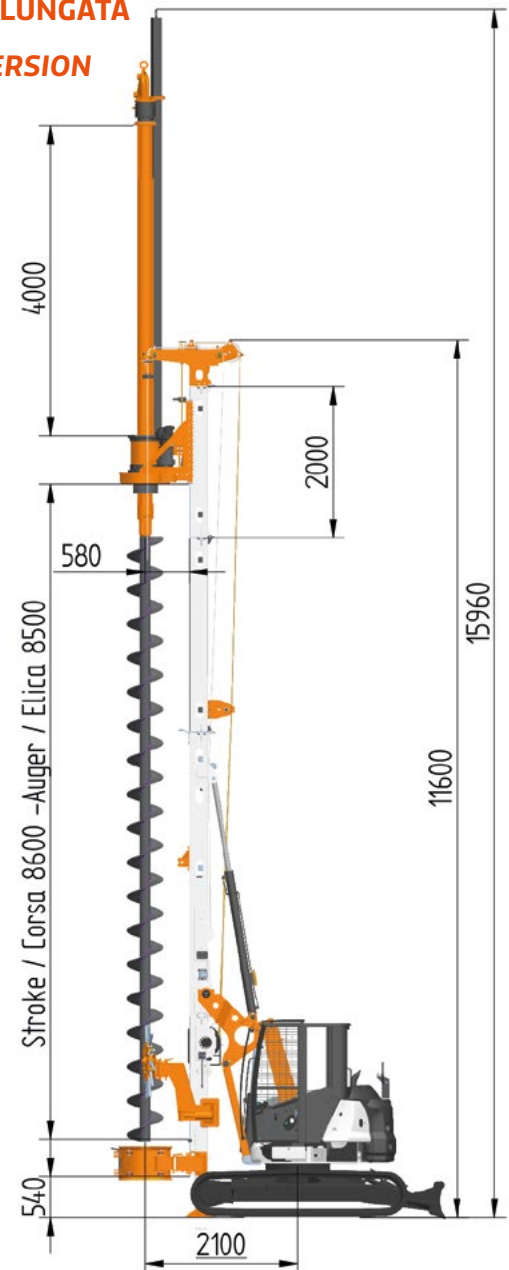

Pali CFA

	<i>CFA bored piling</i>	
Passaggio interno	Inner passage	ø 3 - 4 - 5 in
Diametro max	Max diameter	600 mm – 23,6 in
Profondità max	Max depth	6 m – 19,7 ft
Profondità max con prolunga	Max depth with kelly extension	10 m – 32,8 ft
Forza di estrazione con tiro in II	Extraction force on 2nd layer pull	104 kN – 23400 lbs

Pali CFA - allungata

	<i>CFA bored piling - extended</i>	
Passaggio interno	Inner passage	ø 3 - 4 - 5 in
Diametro max	Max diameter	600 mm – 23,6 in
Profondità max	Max depth	8 m – 26,2 ft
Profondità max con prolunga	Max depth with kelly extension	12 m – 39,3 ft
Forza di estrazione con tiro in III	Extraction force on 3rd layer pull	156 kN – 35100 lbs



VERSIONE PER MICROPALI MICROPILING

TT5

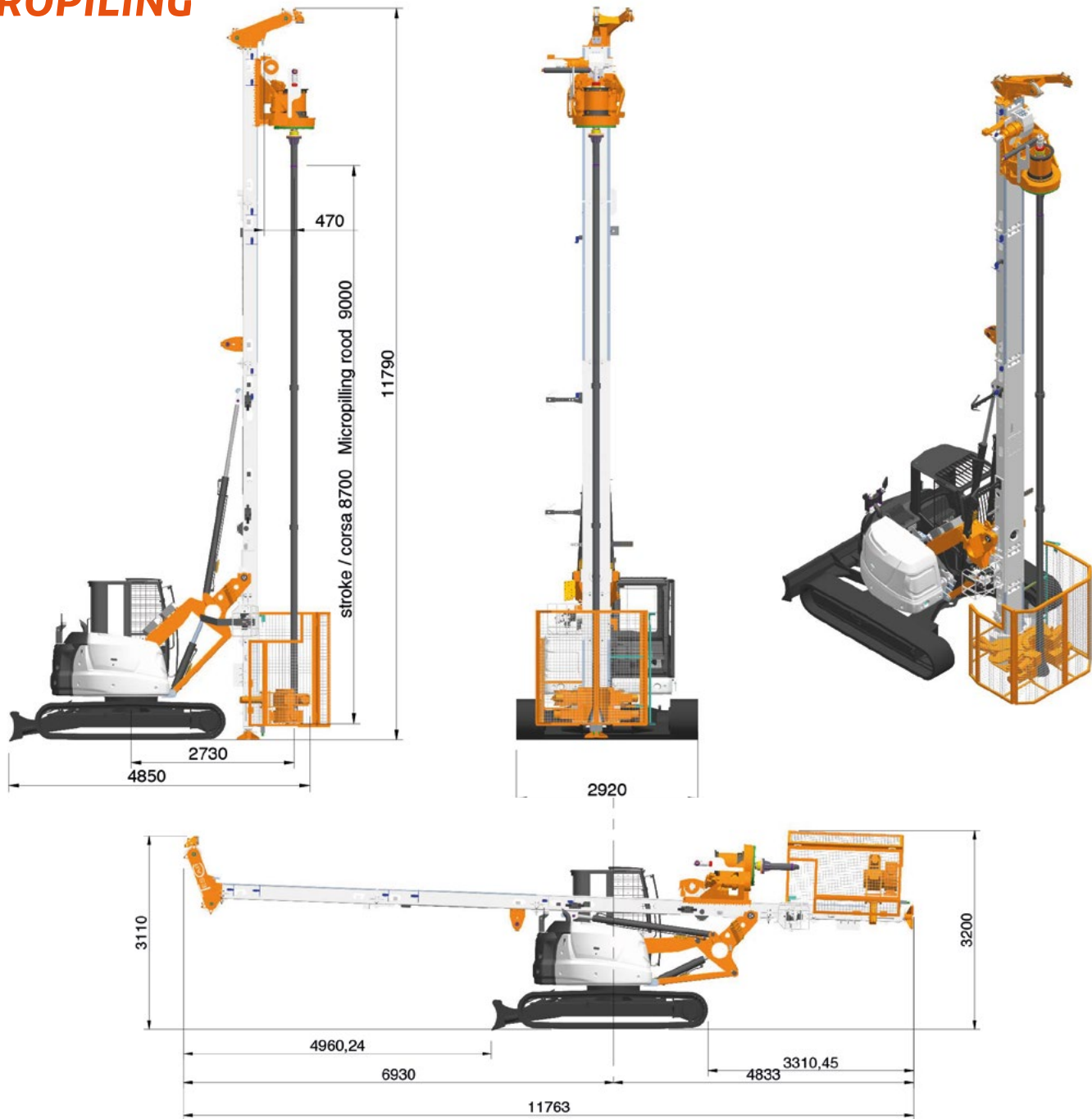

Micropali

Profondità max con aste
Profondità max con eliche
Diametro delle morse
Prolunga mast
Attacco filettato
Testina girevole
Diametro delle aste
Forza Tiro/Spinta
Canotto rotary con ammortizzatore
Piede-mast idraulico
Gabbia di sicurezza
Filocomando
Pompa spurgo

Micropiling

Max depth with rods
Max depth with augers
Diameter of the clamps
Mast extension
Threaded joint
Swivel head
Diameter of the rods
Push/pull force
Rotary sleeve with shock absorber
Hydraulic mast-foot
Safety cage
Wire remote controller
Flushing pump

8500 mm – 27,9 in
9000 mm – 29,5 in
60-380 mm – 2,4-14,9 in
2500 m – 8,2 ft
3 1/2 in Api Regular
1 1/2 in
114 mm – 4,5 in
80 kN – 17985 lbs



I dati tecnici sono indicativi e soggetti a modifiche senza preavviso.
Specifications shown are only indicative and subjected to change without prior notice.

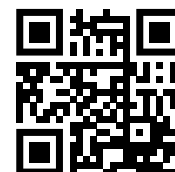

TES CAR®
is a brand licensed to
TONTI TRADING SRL

info@tontitrading.com
+39 071 9300027
www.tescar.com

Registered Office
via Marco Polo, 80
Osimo (AN), Italy

Operating Office
via Flaminia II, 16
Osimo (AN), Italy